

Decorative Base Cover:

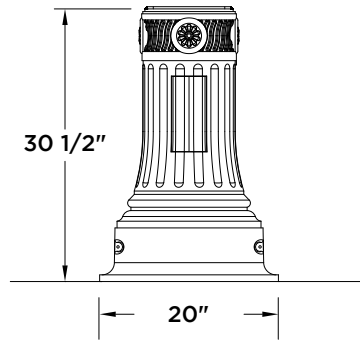

Baseplate:

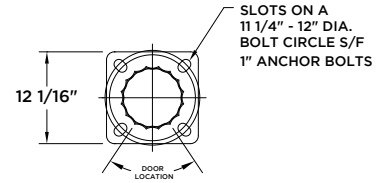

Specifications:

Pole Shaft Options:

Available as Fluted Extruded (FE) 16 flute non-tapered in aluminum, Round Extruded (RE) non-tapered in aluminum, Form Fluted (FF) 16 flute tapered in aluminum or steel and Round Formed (RF) tapered in aluminum or steel.



Fluted Extruded (FE)



Form Fluted (FF)



Round Extruded (RE)



Round Formed (RF)

Decorative Base Cover:

Cast aluminum clam shell with maximum shaft opening of 9.125".

Base Weight*:

49 lbs

*Consult Shaft Detail Charts below for pole shaft weight

Options:

- GFI** > Ground Fault Receptacle
- BA** > Banner Arms
- FPH** > Flower Pot Holder
- FH** > Flag Holder

Finish:

Available in textured or smooth.

How to Order:

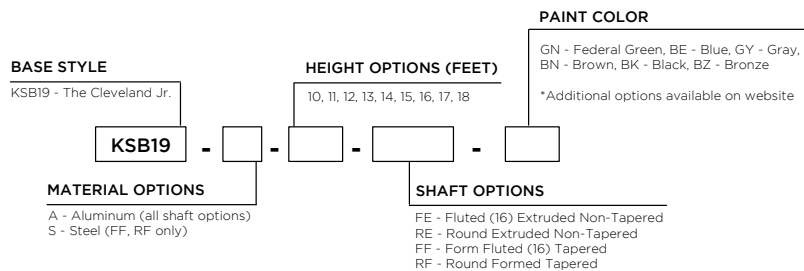

FE ALUMINUM // Shaft Details

Catalog Number	Ht. (ft)	Butt (in)	Tip (in)	Tenon	Wall Thickness (in)	Wt. (lbs)	90 MPH		100 MPH		110 MPH		120 MPH		150 MPH		Anchor Bolt Dia. (in)
							Max EPA (sq ft)	Max Load (lbs)	Max EPA (sq ft)	Max Load (lbs)	Max EPA (sq ft)	Max Load (lbs)	Max EPA (sq ft)	Max Load (lbs)	Max EPA (sq ft)	Max Load (lbs)	
KSB19-A-10-FE	10	5.25	5.25	3.5" x 3.5"	0.25	46	16.8	500	13.3	500	10.7	500	8.8	500	5.2	500	0.75
KSB19-A-11-FE	11	5.25	5.25	3.5" x 3.5"	0.25	50	14.7	500	11.6	500	9.3	500	7.6	500	4.4	500	0.75
KSB19-A-12-FE	12	5.25	5.25	3.5" x 3.5"	0.25	55	12.9	500	10.1	500	8.1	500	6.6	500	3.7	500	0.75
KSB19-A-13-FE	13	5.25	5.25	3.5" x 3.5"	0.25	59	11.4	500	8.9	500	7.1	500	5.7	500	3.1	500	0.75
KSB19-A-14-FE	14	5.25	5.25	3.5" x 3.5"	0.25	64	10.1	500	7.8	500	6.1	500	4.9	500	2.6	500	0.75
KSB19-A-15-FE	15	5.25	5.25	3.5" x 3.5"	0.25	69	8.9	500	6.8	500	5.3	500	4.1	500	2.1	500	0.75
KSB19-A-16-FE	16	5.25	5.25	3.5" x 3.5"	0.25	73	7.8	500	5.9	500	4.5	500	3.5	500	1.6	500	0.75
KSB19-A-17-FE	17	5.25	5.25	3.5" x 3.5"	0.25	78	6.8	500	5.0	500	3.8	500	2.9	500	1.2	500	0.75
KSB19-A-18-FE	18	5.25	5.25	3.5" x 3.5"	0.25	82	5.8	500	4.2	500	3.1	500	2.3	500	0.8	500	0.75

RE ALUMINUM // Shaft Details

Catalog Number	Ht. (ft)	Butt (in)	Tip (in)	Tenon	Wall Thickness (in)	Wt. (lbs)	90 MPH		100 MPH		110 MPH		120 MPH		150 MPH		Anchor Bolt Dia. (in)
							Max EPA (sq ft)	Max Load (lbs)	Max EPA (sq ft)	Max Load (lbs)	Max EPA (sq ft)	Max Load (lbs)	Max EPA (sq ft)	Max Load (lbs)	Max EPA (sq ft)	Max Load (lbs)	
KSB19-A-10-RE	10	4.5	4.5	3.5" x 3.5"	0.25	39	21.0	500	16.6	500	13.5	500	11.2	500	7.0	500	0.75
KSB19-A-11-RE	11	4.5	4.5	3.5" x 3.5"	0.25	43	18.5	500	14.5	500	11.8	500	9.8	500	6.0	500	0.75
KSB19-A-12-RE	12	4.5	4.5	3.5" x 3.5"	0.25	47	16.3	500	12.7	500	10.3	500	8.5	500	5.2	500	0.75
KSB19-A-13-RE	13	4.5	4.5	3.5" x 3.5"	0.25	51	14.4	500	11.2	500	8.9	500	7.4	500	4.5	500	0.75
KSB19-A-14-RE	14	4.5	4.5	3.5" x 3.5"	0.25	55	12.8	500	9.8	500	7.8	500	6.4	500	3.8	500	0.75
KSB19-A-15-RE	15	4.5	4.5	3.5" x 3.5"	0.25	59	11.3	500	8.6	500	6.7	500	5.5	500	3.2	500	0.75
KSB19-A-16-RE	16	4.5	4.5	3.5" x 3.5"	0.25	63	9.9	500	7.4	500	5.8	500	4.7	500	2.7	500	0.75
KSB19-A-17-RE	17	4.5	4.5	3.5" x 3.5"	0.25	67	8.7	500	6.4	500	4.9	500	3.9	500	2.2	500	0.75
KSB19-A-18-RE	18	4.5	4.5	3.5" x 3.5"	0.25	71	7.5	500	5.4	500	4.1	500	3.2	500	1.7	500	0.75

FF ALUMINUM // Shaft Details

Catalog Number	Ht. (ft)	Butt (in)	Tip (in)	Tenon	Wall Thickness (in)	Wt. (lbs)	90 MPH		100 MPH		110 MPH		120 MPH		150 MPH		Anchor Bolt Dia. (in)
							Max EPA (sq ft)	Max Load (lbs)	Max EPA (sq ft)	Max Load (lbs)	Max EPA (sq ft)	Max Load (lbs)	Max EPA (sq ft)	Max Load (lbs)	Max EPA (sq ft)	Max Load (lbs)	
KSB19-A-10-FF	10	5.9	4.5	3.5" x 3.5"	0.182	33	11.9	500	9.4	500	7.6	500	6.2	500	3.6	500	0.75
KSB19-A-11-FF	11	6.04	4.5	3.5" x 3.5"	0.182	37	11.0	500	8.7	500	7.0	500	5.7	500	3.2	500	0.75
KSB19-A-12-FF	12	6.18	4.5	3.5" x 3.5"	0.182	41	10.2	500	8.0	500	6.4	500	5.1	500	2.8	500	0.75
KSB19-A-13-FF	13	6.32	4.5	3.5" x 3.5"	0.182	45	9.5	500	7.4	500	5.9	500	4.7	500	2.5	500	0.75
KSB19-A-14-FF	14	6.46	4.5	3.5" x 3.5"	0.182	49	8.8	500	6.9	500	5.4	500	4.3	500	2.2	500	0.75
KSB19-A-15-F	15	6.6	4.5	3.5" x 3.5"	0.182	54	8.3	500	6.4	500	5.0	500	3.9	500	1.9	500	0.75
KSB19-A-16-FF	16	6.74	4.5	3.5" x 3.5"	0.182	58	7.8	500	5.9	500	4.6	500	3.6	500	1.6	500	0.75
KSB19-A-17-FF	17	6.88	4.5	3.5" x 3.5"	0.182	62	7.2	500	5.5	500	4.2	500	3.2	500	1.4	500	0.75
KSB19-A-18-FF	18	7.02	4.5	3.5" x 3.5"	0.182	67	6.7	500	5.0	500	3.8	500	2.9	500	1.1	500	0.75

RF ALUMINUM // Shaft Details

Catalog Number	Ht. (ft)	Butt (in)	Tip (in)	Tenon	Wall Thickness (in)	Wt. (lbs)	90 MPH		100 MPH		110 MPH		120 MPH		150 MPH		Anchor Bolt Dia. (in)
							Max EPA (sq ft)	Max Load (lbs)	Max EPA (sq ft)	Max Load (lbs)	Max EPA (sq ft)	Max Load (lbs)	Max EPA (sq ft)	Max Load (lbs)	Max EPA (sq ft)	Max Load (lbs)	
KSB19-A-10-RF	10	5.9	4.5	3.5" x 3.5"	0.182	33	13.0	500	10.2	500	8.3	500	6.9	500	4.2	500	0.75
KSB19-A-11-RF	11	6.04	4.5	3.5" x 3.5"	0.182	37	12.0	500	9.4	500	7.6	500	6.3	500	3.8	500	0.75
KSB19-A-12-RF	12	6.18	4.5	3.5" x 3.5"	0.182	41	11.1	500	8.7	500	7.0	500	5.8	500	3.5	500	0.75
KSB19-A-13-RF	13	6.32	4.5	3.5" x 3.5"	0.182	45	10.4	500	8.1	500	6.5	500	5.3	500	3.2	500	0.75
KSB19-A-14-RF	14	6.46	4.5	3.5" x 3.5"	0.182	49	9.7	500	7.5	500	6.0	500	4.9	500	2.9	500	0.75
KSB19-A-15-RF	15	6.6	4.5	3.5" x 3.5"	0.182	54	9.1	500	7.0	500	5.6	500	4.6	500	2.6	500	0.75
KSB19-A-16-RF	16	6.74	4.5	3.5" x 3.5"	0.182	58	8.6	500	6.6	500	5.2	500	4.2	500	2.4	500	0.75
KSB19-A-17-RF	17	6.88	4.5	3.5" x 3.5"	0.182	62	8.0	500	6.1	500	4.8	500	3.9	500	2.2	500	0.75
KSB19-A-18-RF	18	7.02	4.5	3.5" x 3.5"	0.182	67	7.5	500	5.6	500	4.4	500	3.6	500	1.9	500	0.75

FF STEEL // Shaft Details

Catalog Number	Ht. (ft)	Butt (in)	Tip (in)	Tenon	Wall Thickness (in)	Wt. (lbs)	90 MPH		100 MPH		110 MPH		120 MPH		150 MPH		Anchor Bolt Dia. (in)
							Max EPA (sq ft)	Max Load (lbs)	Max EPA (sq ft)	Max Load (lbs)	Max EPA (sq ft)	Max Load (lbs)	Max EPA (sq ft)	Max Load (lbs)	Max EPA (sq ft)	Max Load (lbs)	
KSB19-S-10-FF	10	5.9	4.5	3.5" x 3.5"	0.12	65	34.4	500	27.6	500	22.7	500	18.9	500	11.7	500	1.00
KSB19-S-11-FF	11	6.04	4.5	3.5" x 3.5"	0.12	73	32.4	500	26.0	500	21.3	500	17.7	500	10.9	500	1.00
KSB19-S-12-FF	12	6.18	4.5	3.5" x 3.5"	0.12	80	30.7	500	24.6	500	20.1	500	16.7	500	10.2	500	1.00
KSB19-S-13-FF	13	6.32	4.5	3.5" x 3.5"	0.12	88	29.3	500	23.4	500	19.1	500	15.8	500	9.6	500	1.00
KSB19-S-14-FF	14	6.46	4.5	3.5" x 3.5"	0.12	96	28.1	500	22.4	500	18.3	500	15.1	500	9.1	500	1.00
KSB19-S-15-FF	15	6.6	4.5	3.5" x 3.5"	0.12	104	27.0	500	21.5	500	17.5	500	14.4	500	8.6	500	1.00
KSB19-S-16-FF	16	6.74	4.5	3.5" x 3.5"	0.12	113	26.0	500	20.7	500	16.8	500	13.8	500	8.2	500	1.00
KSB19-S-17-FF	17	6.88	4.5	3.5" x 3.5"	0.12	121	25.0	500	19.9	500	16.1	500	13.2	500	7.8	500	1.00
KSB19-S-18-FF	18	7.02	4.5	3.5" x 3.5"	0.12	130	23.9	500	19.0	500	15.4	500	12.6	500	7.3	500	1.00

RF STEEL // Shaft Details

Catalog Number	Ht. (ft)	Butt (in)	Tip (in)	Tenon	Wall Thickness (in)	Wt. (lbs)	90 MPH		100 MPH		110 MPH		120 MPH		150 MPH		Anchor Bolt Dia. (in)
							Max EPA (sq ft)	Max Load (lbs)	Max EPA (sq ft)	Max Load (lbs)	Max EPA (sq ft)	Max Load (lbs)	Max EPA (sq ft)	Max Load (lbs)	Max EPA (sq ft)	Max Load (lbs)	
KSB19-S-10-RF	10	5.9	4.5	3.5" x 3.5"	0.12	65	37.1	500	29.8	500	24.5	500	20.5	500	12.9	500	1.00
KSB19-S-11-RF	11	6.04	4.5	3.5" x 3.5"	0.12	73	35.0	500	28.1	500	23.0	500	19.2	500	12.1	500	1.00
KSB19-S-12-RF	12	6.18	4.5	3.5" x 3.5"	0.12	80	33.2	500	26.6	500	21.8	500	18.2	500	11.4	500	1.00
KSB19-S-13-RF	13	6.32	4.5	3.5" x 3.5"	0.12	88	31.7	500	25.3	500	20.8	500	17.3	500	10.8	500	1.00
KSB19-S-14-RF	14	6.46	4.5	3.5" x 3.5"	0.12	96	30.4	500	24.3	500	19.9	500	16.6	500	10.3	500	1.00
KSB19-S-15-RF	15	6.6	4.5	3.5" x 3.5"	0.12	104	29.3	500	23.3	500	19.1	500	15.9	500	9.9	500	1.00
KSB19-S-16-RF	16	6.74	4.5	3.5" x 3.5"	0.12	113	28.2	500	22.5	500	18.4	500	15.3	500	9.5	500	1.00
KSB19-S-17-RF	17	6.88	4.5	3.5" x 3.5"	0.12	121	27.2	500	21.6	500	17.6	500	14.6	500	9.1	500	1.00
KSB19-S-18-RF	18	7.02	4.5	3.5" x 3.5"	0.12	130	26.0	500	20.7	500	16.9	500	14.0	500	8.6	500	1.00

1-24-2020