

# K366 HARBOR SIDE - LED



Designed to add style and function to marinas, pathways, and waterfronts, the K366 Harbor Side, offers rugged aesthetics and a high quality, well-engineered luminaire. Available in both post top and pendant formats to coordinate pathways and roadways alike.



**KING  
LUMINAIRE**

## PRODUCT SPECIFICATIONS

### P4 LED ENGINE

Light engine shall include an array of Cree X-Series high power LEDs (light emitting diodes). The emitters shall be mounted to a metal core circuit board using SMT technology. The LEDs and circuit boards shall then be mounted to a high performance heat sink. External light control shall consist of high precision refractive lenses mounted above the LED emitter arrays in such a way to achieve optimum uplight control. The lenses shall also control horizontal light distribution so that either Type II, III, IV or V IESNA distribution patterns are achieved.

### LENS

The K366 Harbor Side has an acrylic lens with a minimum body thickness of 0.25". The lens is secured by means of a cast A319 aluminum holding ring. The lens is sealed by means of a continuous neoprene gasket applied to the lens frame to provide an IP66 ingress protection rating.

### DECORATIVE BODY

The luminaire shall consist of a heavy Grade A319 cast aluminum housing that acts as the enclosure for the engine and is of adequate thickness to give structural rigidity. The engine must be affixed to the inside of the housing with stainless steel screws.

### DRIVER

The LED universal dimmable driver will be class 2 and capable of 120 - 277V or 347 - 480V input voltage, greater than 0.9 power factor, less than 20% total harmonic distortion. The case temperature of the driver can range from -40°C up to 70°C. Each LED system comes with a standard surge protection designed to withstand up to 20kV/10kA of transient line surge as per IEEE C62.41.2 C High. An in-line ferrite choke is utilized to provide protection against EFT's. The driver assembly will be mounted on a heavy duty fabricated galvanized

steel bracket to allow complete tool-less maintenance. Dimming capable using 1-10vdc (10% to 100%), 10v PWM, or resistance.

### PHOTOMETRICS

Fixtures are tested to IESNA LM79 specifications. These reports are available upon request.

### CHROMATICITY

High output LEDs come standard at 3000K & 4000K (+/- 300K) with a minimum nominal 70 CRI. Additional CCT emitters are available upon request.

### LUMEN MAINTENANCE

Reported (TM21) and Calculated (L70) reports are available upon request with a minimum calculated value of 100,000 hrs.

### WIRING

All internal wiring and connections shall be completed so that it will be necessary only to attach the incoming supply connectors to Mate-N-Lok connectors or to a terminal block. Mate-N-Lok shall be certified for 600V operation. Internal wire connectors shall be crimp connector only and rated at 1000V and 150°C. All wiring to be CSA certified and/or UL listed, type SFF-2, SEWF-2, or SEW-2 No. 14 gauge, 150°C, 600V, and color coded for the required voltage.

### THERMALS

Fixtures tested by a DOE sanctioned test facility to determine the maximum in-situ solder-point or junction-point temperatures of the LED emitters. This report is available upon request.

### FINISH

Housing is finished with a 13 step KingCoat™ SuperDurable polyester TGIC powder coat. Standard colors include strobe white, brown metal, marina blue, gate gray, Chicago bronze, standard gold, standard black, federal green and rain forest. Please see our website for a complete list of colors. Additional RAL or custom color matches are available.

### MISCELLANEOUS

All exterior hardware and fasteners, wholly or partly exposed, shall be stainless steel alloy. All internal fasteners are stainless steel or zinc coated steel. All remaining internal hardware is stainless steel, aluminum alloy, or zinc coated steel.

### WARRANTY

The K366 Harbor Side LED luminaire comes with a 7 year limited warranty.

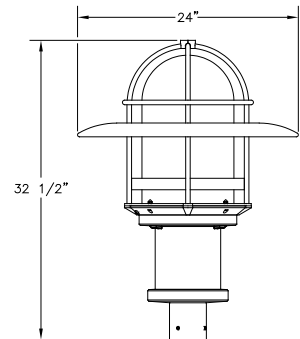

### CERTIFICATION:

CSA US Listed  
Suitable for wet locations  
ISO 9001  
IP66  
ARRA Compliant  
LM79 / LM80 Compliant

### DRIVER INFO:

>0.9 Power Factor  
<20% Total Harmonic Distortion  
120V - 277V or 347 - 480V  
-40°C Min. Case Temperature  
60°C Max. Case Temp. (T1)  
70°C Max. Case Temp. (P4)  
Surge Protection: ANSI 136.2  
extreme level 20kV/10kA  
Dimming Capable: 1-10vdc

### EPA:

1.13 sq. ft.

### FIXTURE WEIGHT:

49 lbs



## Fixture Formats

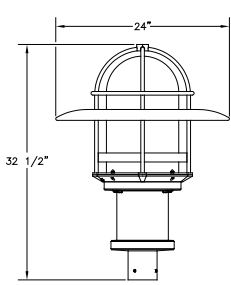

Post Top  
Single Shroud

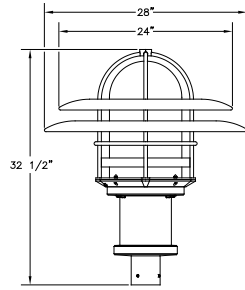

Post Top  
Double Shroud

## HOW TO ORDER

